

4

Item Master and Bill of Material

MGT2405, University of Toronto, Denny Hong Mo Yeh

The enterprise resource planning (ERP) system plans and controls all resources in an enterprise. Material requirement planning (MRP) is the engine of the ERP system that schedules the purchase and manufacturing of the materials. The plans for other resources are derived from it. MRP calculates the planned order releases from the MPS and the fundamental data. If the fundamental data is incorrect, the MRP will fail. Key fundamental data for MRP include the item master, bill of material, routing, and bill of resources. Item master and bill of material describe the products, while routing and bill of resources describe the production processes. We will discuss item master and bill of material in this chapter. Routing, bill of resources, rough-cut capacity planning and capacity requirement planning will be discussed in the next chapter.

Item Master

The item master file describes the attributes of a company's items, which include raw materials, works-in-process, semi-finished goods, and finished goods. Some items recorded in the item master file do not actually exist. We call these items phantoms. The number of attributes of an item is very large, and we therefore find it useful to organize them into five groups: general attributes, attributes for planning, attributes for inventory, attributes for inspection, and attributes for costing.

- *General attributes*

General attributes are the attributes of an item commonly used in many modules in the ERP system. These include part number, name, specification, unit of measurement for quantity, product line, product sub-line, inventory type, inventory sub-type, drawing number, engineering change number, etc. The product line and sub-line are used to sort out the items for item master reports, material requirement reports, sales amount reports, cost reports, etc. The inventory type is usually defined as the main ingredient

of the parts, such as iron, steel, brass, plastic, etc., and is used to analyze the cost of the parts. Inventory sub-types are used when further classification is required. The drawing number is used to fetch the drawings from the computer aided design system and attach them to the manufacturing or purchasing documents. The engineering change (EC) number is used to link the ERP system to an outside workflow control system for monitoring the documents of an EC in progress, or for retrieving the record of the last EC when it has been closed.

- *Attributes for planning*

The attribute “source” indicates the avenues for procuring the parts, including purchasing, manufacturing, subcontracting, and transferring. Subcontracting is the practice of sending the production work to an outside subcontractor. Transferring is a procedure where a part from one department of an organization is transferred to another department of the same organization. For a transferred item, a department number must be entered into the “transfer from” attribute.

The attribute “phantom” indicates that a part does not actually exist. For example, a product family consisting of similar products with optional parts is a phantom. It does not exist physically, but is used in planning the future demand for end products. This issue will be discussed in the section on BOM.

The attribute “critical part” is used to recognize parts that are essential to the MPS procedure. An MPS is feasible only when the critical parts are available. If an item is indicated as an “MPS item”, it will be processed in MPS related procedures. If an item is a “planned order” item, its planned orders will be automatically generated by the MRP system.

The attribute “order policy” indicates the policy used to replenish that item. If the policy is re-order point (ROP), then “order point” and “economic order quantity” must be specified. If the ordering policy is MRP, then the “lot sizing rule” must be determined. If a “period order quantity” policy is chosen, the “order interval” must be specified. If a policy is “fixed order quantity”, the “fixed quantity” must be determined.

The attribute “multiplier” specifies that the order quantity must be a multiple of the multiplier. This attribute usually relates to the size of the containers. The “minimal

order quantity” and “maximal order quantity” are used to limit the order quantity to a specified range. The “BOM Code” and “Routing code” specify the BOM and routing that item uses.

- *Attributes for inventory*

All items have records in the item master file, but not all of them require inventory control. The attribute “inventory control” indicates whether the inventory of a particular item needs control. If an item’s lot number must be recorded and traced, the “lot control” field is set to “yes”. Users are required to enter a lot number or serial number when a lot-control item is received or released.

The attribute “ABC Classification” sorts the items in decreasing order of annual dollar volume or other criteria. Items are then split into either A, B, or C classes. The ABC classification enables users to save effort and money by identifying which items are high-dollar-volume items (A class) so that the resources can be allocated away from low-dollar-volume items to higher priority items. The C class items are sometimes stored on the shop floor and replenished through a re-order point method or two-bin system. When this is the case, the attribute “bulk issue” is set as “yes”, and the MRP will skip the calculation of those items’ planned order releases.

The “cycle count interval” is the interval between two cyclic counts for an item. Other attributes include container capacity, volume, unit of volume, weight, unit of weight, etc.

- *Attributes for inspection*

Inspection is the measuring, testing, or gauging of one or more characteristics of a product or service. The results of inspection are compared with specified requirements in order to determine whether conformity is achieved for each characteristic (Apics, 1995).

Inspection attributes in the item master file include inspector, inspection class, inspection level, sampling standard, yield, etc. Inspection classes include all inspection, no inspection, and sampling inspection. In sampling inspection, the inspection level is used to determine the sample size. Sampling standard specifies an increase or decrease in sample size, depending on historical inspection results. When a continuing series of lots is considered, the acceptable quality level (AQL) is used to

specify the limit of a satisfactory process average. Yield is the ratio of usable output to the corresponding input for a process. All the values of the attributes in the item master are standard rather than actual.

- *Attributes for costing*

We must determine the manufacturing cost of each non-phantom item, including direct material, direct labor, and overhead. Items not related to manufacturing, such as R&D testing items, are treated as expenses and are not considered in product manufacturing cost. The direct or indirect materials related to manufacturing are recorded as inventory in the accounting system. The attribute “inventory/expenditure” indicates, on receipt of an item, whether the transaction is recorded as debit inventory or debit expense with respect to the credit accounts.

If the item is an “inventory” item, it may contribute direct material, direct labor or overhead costs to its parents. The “cost type” field specifies whether the cost of a component is allocated to a specific cost category or to all of that component’s parents. Costs allocated to parents are further broken down into more specific cost categories.

For example, if the cost type of an item is specified as “assembly labor”, then the labor cost will be added on to the assembly labor of its parents. If it is not specified, then it is allocated to the direct labor of the parents and then allocated to various types of direct labor, say, assembly and inspection labor, according to a predetermined percentage.

The attribute “standard coefficient” is used for calculating the unit material cost when the unit-of-measurements used in purchasing and inventory management are different. For example, suppose we buy various casting parts from a supplier at a unit price of \$2 per kilogram regardless of what part it is. For inventory management, the unit-of-measurement is “ea” and the cost of each cast is determined according its weight. The “standard coefficient” in this example is the weight. If an item weighs 1.2 kilograms, then its “standard coefficient” is 1.2 and its cost is \$2.4.

Bill Of Material

The item master file describes the attributes of individual items. The bill of material file describes the relationships among the items.

- *Basic structure of BOM*

A BOM consists of records that describe the relationship between a parent item and its component items. The simplest BOM record includes three fields: parent part number, component part number, and the quantity of components used by per parent. If a parent has m components and each component, also being a parent, has n components, then there are $m \times n$ records in these $m+1$ bills of material. The BOM of a part is logically described with a tree structure. In this book, we define BOM as a single-level tree structure representing the relationship between a parent and all its components. Several bills of material together constitute a product structure.

- *BOM code*

In a company, different products usually have similar BOM structures. The “BOM code” is used to simplify the maintenance of BOM and to avoid redundancy of BOM records. Suppose two items use the same components but have different process methods or colors, etc..., or their part numbers are different but have identical bills of material. A BOM code, instead of the part number, is used to identify the BOM. Different items may have the same BOM code. This enables several items to share an identical BOM.

Using BOM codes also provides flexibility in the case when an item requires a different BOM after an engineering change. The BOM can then be copied, revised, and assigned a new BOM code for this new item while other items continue to use the original BOM.

If a customer makes only a small change to the standard BOM, we can simply modify the existing BOM and assign a new BOM code to the original part number. When the order is closed, the item is related back to the old BOM code. It is sometimes possible for an item to have more than one BOM codes at different times.

BOM codes are maintained in the planning section of the item master file. Each item must have a BOM code. If not specified, the default value of the BOM code of an item is its part number. Part numbers are unique for each item, but BOM codes are not. A part number has at most one BOM code, while a BOM code can be shared by several part numbers.

- Key fields making a unique BOM record

The key fields that make up a unique BOM record include the BOM code, component part number, start/end date, and reference number. Since different items may share a BOM, the “BOM code” rather than the “parent part number” is used as the key to a BOM record.

A new component generated by an engineering change exists along with its old version in a BOM. The system may misunderstand that both old and new components are required. The “start/end date” field ensures that only effective BOM records are fetched by the system. The old BOM is used before the start date of the new BOM; the new BOM is used after that.

Components of a parent may be required at different times or locations. In this case, several BOM records would have the same BOM code, component part number, and start/end date. Therefore, the fourth field, reference number, is introduced to make BOM records unique. A parent-component relationship with more than one reference number indicates that an identical component is used at various times or in different locations. Fields in a BOM file such as “lead time adjustment” and “use location” are used together with “reference number” to cope with the above situation. These topics are discussed in depth later.

- *Occasional special order consideration*

Some customers occasionally place orders for non-standard products or standard products with special modifications. *Add/delete BOM* is used to cope with this situation. BOM of standard products are copied and modified when the customer orders are received. These BOM are then used in MPS, MRP, purchasing, picking, manufacturing, shipping, and costing. When the orders are delivered and related data processes are completed, these temporary BOM are deleted. The above procedure is called Add/Delete BOM.

- *Build-on-the-line parts consideration*

An inventory-controlled part is produced and stocked by shop orders and is withdrawn from the inventory to produce its parent through another shop order and accompanied picking orders. If the production of the parents and the components are simultaneous, we may combine the shop orders for components and the parent into a shop order to produce the parent directly from the materials of the components. In this case, the

components are called built-on-the-line parts. They are built on the line and then transported immediately to their parents' production line instead being stored in inventory.

The records of these BOM are defined as "phantoms," indicating that the parent-component relationships do not exist. For example, suppose C makes B and B makes A. If A is to be made directly from C, then the BOM record for A-B relationship is a phantom. When a picking order is generated, the components are skipped, and direct relationships between the parent and the components of the components are established. A new BOM code is assigned to this new BOM. When it is to be used, the BOM code of the parent in the item master file is changed into the new one.

- *Replacement parts consideration*

In building a product, a shortage of material does not necessarily cause a manufacturing interruption or a schedule change. Some materials can replace other materials when it is critical to proceed with production. An *alternate BOM* is a bill of material composed of different components that can be used to manufacture the same parent. It is usually less desirable than the primary BOM and is only used in special cases. The BOM code of the parent item is modified to that of the alternate BOM before using alternate parts to replace primary parts.

- *Identical parts used in different locations*

An identical component of a parent may be used in different processes. Therefore, they must be sent to different manufacturing units or locations. When picking orders are generated by BOM, components are sorted by locations. If this component is used at n locations, n BOM records are established. Each record has the same BOM code, component part number, start/end date, but different reference numbers. There are n reference numbers for these BOM records. The "quantity-per" for each record is the usage of the component in the corresponding location. Since the picking orders are sorted by "use location", an identical component is issued to several specified locations.

- *Identical parts used in different times*

For products with very long manufacturing lead-time, an identical part may be required in different periods and should be issued or released many times. If an identical component is used at n different times, there are n BOM records for this

parent-component relationship. These identical item BOM records are distinguished by “reference number”, and each has a predetermined “offset time”. A positive offset time advances the release and receipt of the parts. A negative offset time is used to postpone the release and receipt of the parts.

- *Options and Accessories consideration*

“*Feature*” is a distinctive characteristic of a product. There are two factors determining the features: options and accessories. An accessory is also called an attachment when it must be attached to the product. Replacement parts are chosen by the manufacturers, unknown to the customers, and are not related to the characteristics of a product. However, options and accessories are choices made by the customers.

Options or accessories are normally located at the level next to the end products. An option means a mandatory choice from a limited selection. An accessory enhances the capabilities of the product but is not necessary for the basic function of the product. Options are choices for required components while accessories or attachments are for added components. For example, when ordering a new car, a customer must choose one of several engine sizes, but does not necessarily need to buy a DVD system at all. Engine size is an option while a DVD system is an attachment. The sales order configuration system helps users to choose options and accessories and builds a BOM for a specific order.

In a BOM, each parent-component relationship is defined as standard, option, or accessory, if it is not a phantom relationship. For an option or accessory BOM, “quantity-per” is the quantity of the chosen component used by a parent. The “reference numbers” of all the options or accessories for a part are identical.

Some bills of material are used only for planning. The quantity-per’s of their components are the percentages of the options or the accessories being chosen. Planning BOM will be discussed in the next section. Reference number is not required for a planning BOM, regardless of whether it is for an option or an accessory.

In summary, the features of a BOM include standard, phantom, option, accessory, and planning. The attribute “feature” specifies the feature for each BOM. Its default value is “standard”.

- **Scrap rate and Yield**

Scrap may occur when components are transformed into a parent. Since a component has different scrap rate in producing different parents, the scrap rate is recorded in the BOM file in order to increase the gross requirements and account for the anticipated loss. When the planned order releases of the components are calculated by the MRP system, the requirements of the components are enlarged to compensate for the scrap rate.

Yield is the ratio of usable output of an item from a process to its input. It has nothing to do with its components. Therefore, yield is an attribute of the item master file. For example, suppose a parent item's yield is 98%, and the scrap rate of one of its components is 5%. When the required quantity of the parent is 980, the scheduled quantity should be 1000 ($980/0.98$) for the parent, and the gross requirement for the component should be 1053 ($1000/0.95$).

Planning Bill of Material

Artificial groupings of items used to facilitate planning are called pseudo bill of material or planning bill of material.

- *Super BOM*

Super BOM is a type of bill of material located at the top level in the product structure. Super BOM ties together various modular bills of material and possibly a common parts bill of material to define an entire product family. The quantity-per for each relationship represents the forecast percentage of demand of each module. The master scheduled quantities of the parent item of the super bill, i.e., the product family, are exploded to create requirements for the modules and common parts.

- *Modular BOM*

A type of planning bill of material that is arranged in product modules or options. It is used in the planning of assemble-to-order products with many options.

- *Common parts BOM*

A type of planning bill of material that groups common parts for a product or a product family into one bill of material, structured to a phantom parent item.

- *Manufacturing BOM*

Planning bills are used in the planning stage; manufacturing bills are used in the execution stage. Execution stage starts from the receiving of the customer orders. Manufacturing BOM describes the configuration of a product ordered by a customer. Manufacturing BOM is obtained from the bills of material of options and accessories.

We now summarize the application of various BOM. In master scheduling stage, we schedule the production of product families and using super BOM, modular BOM and common part BOM to schedule the modules and common parts. Then, material requirement plans of the components of the modules and common parts are obtained by applying standard BOM to the modules and common parts. At receiving a customer order, we configure the manufacturing BOM with the help of optional and attachment BOM. In the manufacturing stage, materials are picked and issued to the shop floor by using the manufacturing BOM.

Case Study: Lamp Sets

Tailight Company produces various types of lamp sets. The lamp sets consist of all possible combinations of bases, shades, plugs, and common parts, as shown in Figure 1. The base modules and plug modules are manufactured with purchased parts shown in Figure 2.

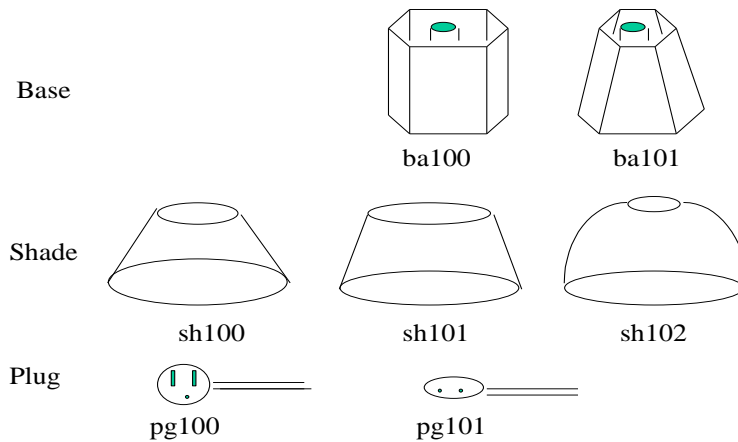

Figure 1: Lamp Set

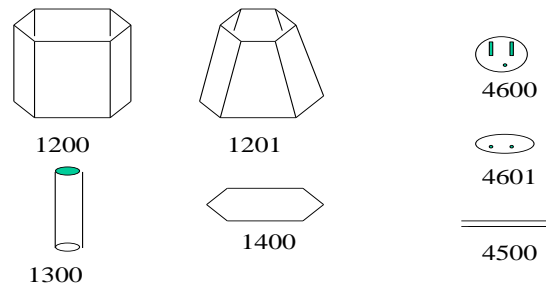

Figure 2: Base Module and Plug Module

Since there are 2 options for the base module, 3 options for the shade module, and 2 options for the plug module, there are 12 end products that customers may order. It is difficult to forecast the customer demands for all the end products. Tailight defines a phantom item Laxxx as a product family representing the 12 lamp sets. Laxxx is not a real product, and no customer places order for it. It is for forecasting and planning. The BOM of Laxxx is shown in Figure 3. Laxxx consists of four components: basemod, shademod, plugmod, and pseudocompart. These components are all phantoms. Each of base module, shade module and plug module represents a group of optional parts. Pseudocompart is a part number representing a part or a group of parts used by all the products. All the modules and pseudo common parts do not physically exist. A super BOM links the phantom product family to the modules and pseudo common parts. MPS items include all the phantom product families, the modules and the pseudo common parts. Super BOM explodes master scheduled product families to obtain the gross requirements for the non-phantom modules and common parts and inputs them into the MRP system. Based on the MPS of phantom item Laxxx, the system calculates the demands for the modules and common parts which is then inputted into the MRP procedure to obtain the planned order releases and receipts for the lower level items. The modules are also master scheduled. This is an example of multilevel master production scheduling technique to be discussed in the chapter on MPS.

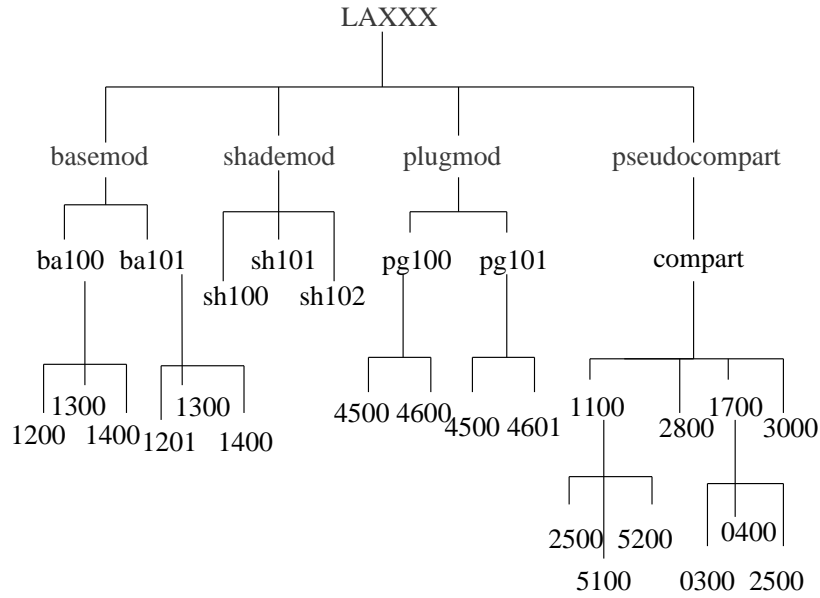

Figure 3: BOM of the Lamp Set

Table 1: Super BOM

Parent Part No.	Component Part No.	Quantity Per	Feature
LAXXX	basemod	1	P
LAXXX	shademod	1	P
LAXXX	plugmode	1	P
LAXXX	pseudocompart	1	P
basemod	ba100	0.6	P
basemod	ba101	0.4	P
shademod	sh100	0.1	P
shademod	sh101	0.3	P
shademod	sh102	0.6	P
plugmod	pg100	0.1	P
plugmod	pg101	0.9	P
pseudocompart	compart	1	P

Remark: P: Planning.

The BOM of a group of module is called “modular bill”. The parent item of a modular bill is a phantom modular part. Similarly, the parent item of a common part BOM is a phantom common part. Super bill, modular bill and common part bill are normally used together, and are defined as “planning BOM”. Table 2 and Table 3 show the BOM of the components of the modular bill and common part bill, respectively.

Table 2: BOM of the Modules

Parent Part No.	Component Part No.	Quantity Per	Feature
ba100	1200	1	S
ba100	1300	1	S
ba100	1400	1	S
ba101	1201	1	S
ba101	1300	1	S
ba101	1400	1	S
pg100	4500	1	S
pg100	4600	1	S
pg101	4500	1	S
pg101	4601	1	S

Remark: S: Standard.

Table 3: BOM of the Common Parts

Parent Part No.	Component Part No.	Quantity Per	Feature
compart	1100	1	H
compart	1700	1	H
compart	2800	1	S
compart	3000	1	S
1100	2500	1	S
1100	5100	1	S
1100	5200	1	S
1700	0300	1	S
1700	0400	1	S
1700	2500	1	S

Remark: H: Phantom

In Table 3, we clearly see that 1100 and 1700 are built-on-the-line parts. Planning bills are used in the planning stage only. In the execution stage, manufacturing bills of material, or M-bills, are used to enter customer orders, generate shop orders, generate picking orders, etc. Phantom parts are not used in the execution stage. The part numbers of the exact end products must be specified in customer orders, manufacturing orders, and picking orders. The manufacturing bills of material are created with the optional BOM shown in Table 4. Reference numbers are used in Table 4 to facilitate the configuration of a product. Examples of manufacturing BOM are shown in Table 5. In a manufacturing BOM, the parent must be non-phantom, but the components can be a phantom. In Table 5, the phantom “compart” is a component of the end product. Phantom components will be skipped in BOM explosion.

Table 4: Optional BOM

Parent Part No.	Component P_No	Reference No	Qty-per	Feature
Laxxx	ba100	10	1	O
Laxxx	ba100	10	1	O
Laxxx	sh100	20	1	O
Laxxx	sh101	20	1	O
Laxxx	sh102	20	1	O
Laxxx	pg100	30	1	O
Laxxx	pg101	30	1	O

Remark: O: Optional.

Table 5: Manufacturing BOM

Parent Part No.	Component Part No.	Quantity Per	Feature
La000	ba100	1	S
La000	sh100	1	S
La000	pg100	1	S
La000	compart	1	S
La121	ba101	1	S
Lz121	sh102	1	S
La121	pg101	1	S
La121	compart	1	S

Case Study: Chemical Products

Kemico Company produces various types of chemicals. Among the products, some chemicals are ordered regularly. These chemicals are produced according to sales forecasts and stocked in storage tanks. The chemicals in the storage tanks are packaged into containers specified by customer orders before shipment. Other products are not ordered continuously and are therefore not manufactured before customer orders are received. Manufacturing processes proceed in reaction tanks and mixture tanks when the customer orders are received. End products are packaged into specified containers from the mixture tanks. Before installing a computerized information system, Kemico defined its end products to be finished chemicals and ignored the packaged chemicals. That is, there is a part number for each chemical and each container, but no part numbers for chemicals contained in the containers. The chemicals are at the top level of bills of material, but containers are perceived as packaging materials and are not included in BOM file. The

unit-of-measurement for the chemicals is kilogram, although they are physically stored in tanks or various containers. When the inventories are counted, people calculate the weights of the chemicals manually since the inventories are recorded in kilograms. As an ERP system was to be installed in Kemico, the part number system was reviewed. End products were defined to be the chemicals packaged in a container rather than the chemicals themselves. The chemicals in the tanks are defined as inventories of semi-finished goods. The unit-of-measurement for the end products is “each” and for semi-finished goods, kilogram. The semi-finished goods are MPS items. Forecasts are done for chemical requirements in kilograms. The following is a simplified scenario.

There are 2 types of chemicals in three kinds of containers. The part numbers for chemicals are A and B; those for containers are 1, 2, and 3. Suppose A is the regularly ordered item, and B is the make-to-order item. Table 6 is part of the item master file.

Table 6: Item master

Part No	Part Name	UM	MPS Item	Invt Mgt	Phantom
A1	Chemical#1/20kg	Ea	N	Y	N
A2	Chemical#1/50kg	Ea	N	Y	N
A3	Chemical#1/200kg	Ea	N	Y	N
B1	Chemical#2/20kg	Ea	N	N	N
B2	Chemical#2/50kg	Ea	N	N	N
B3	Chemical#2/200kg	Ea	N	N	N
A	Chemical#1	Kg	Y	Y	N
B	Chemical#2	Kg	Y	N	N
1	Container-20kg	Ea	N	Y	N
2	Container-50kg	Ea	N	Y	N
3	Container-200kg	Ea	N	Y	N

Part of the BOM file is shown in Table 7.

Table 7: BOM

Parent	Component	Qty-Per	Feature
A1	A	20	S
A1	1	1	S
A2	A	50	S
A2	2	1	S
A3	A	200	S
A3	3	1	S

Item Master and Bill of Material

BOM of A and B are recipes of the chemicals. Manufacturing shop orders are issued for A, B1, B2, and B3. Packaging shop orders are issued for A1, A2, and A3.